

I'm the superintendent of the mine. Last night the evening shift entered the mine at 3:00 pm for their normal shift. The 12 men on the evening shift worked until 9:30 pm without incident.

At 9:00 pm the belt examiner walked the slope belt out. At 9:30 pm the belt examiner heard what sounded like an explosion. Upon investigation he found the explosion doors to the fan were open, and power to the mine had been lost.

The belt examiner could not communicate with the crew underground and attempted to enter the mine by the slope belt. He encountered a rock fall on the slope belt and returned to the surface.

The mine is ventilated with two, 300 ft shafts (Intake & Return). The intake shaft is equipped with a cage hoist used to transport personnel & supplies into the mine. The return shaft is equipped with an Emergency hoist which can only carry 5 people safely.

At 11:00 pm the power had been restored to the surface. The power to the underground is locked out and guarded. The power center underground can be energized at your request.

At 11:15 pm a call came from underground. The section foreman and 5 men were located at the emergency hoist. The hoist cage was lowered and the foreman loaded the hoist to capacity and sent it outside. The hoist cage was sent back in the mine, but we have no further communication with the underground.

At 11:30 pm the explosion doors were closed and ventilation can be restored at your request. Once the exhaust shaft is energized it cannot be turned off, reversed, or stalled.

Your team will enter the mine using the man hoist at the intake air shaft.

There is a back-up team on the surface. All agencies have been notified.

The map is not up-to-date.

This is all the information I have at this time.

.

.

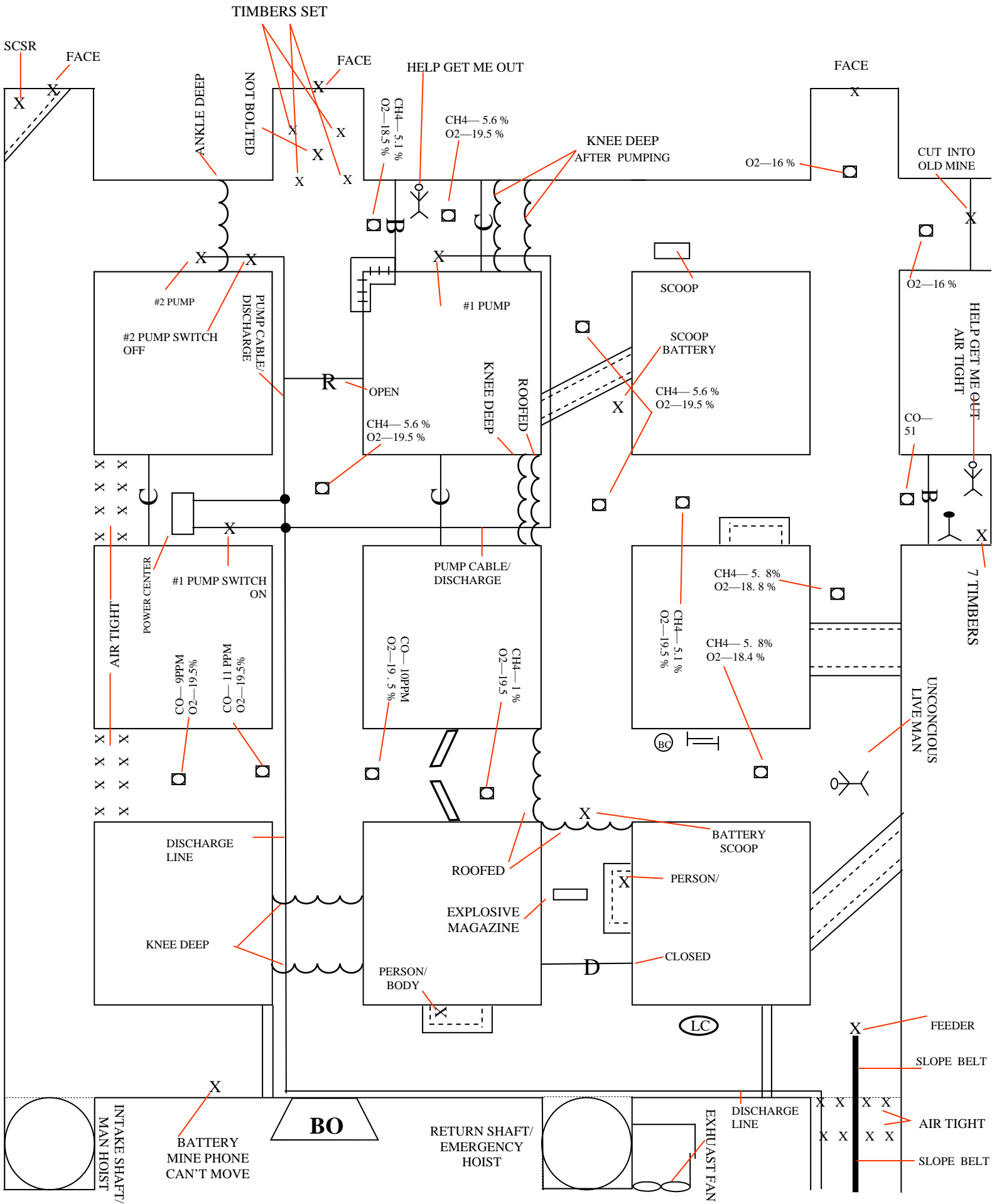

1ST VENTILATION

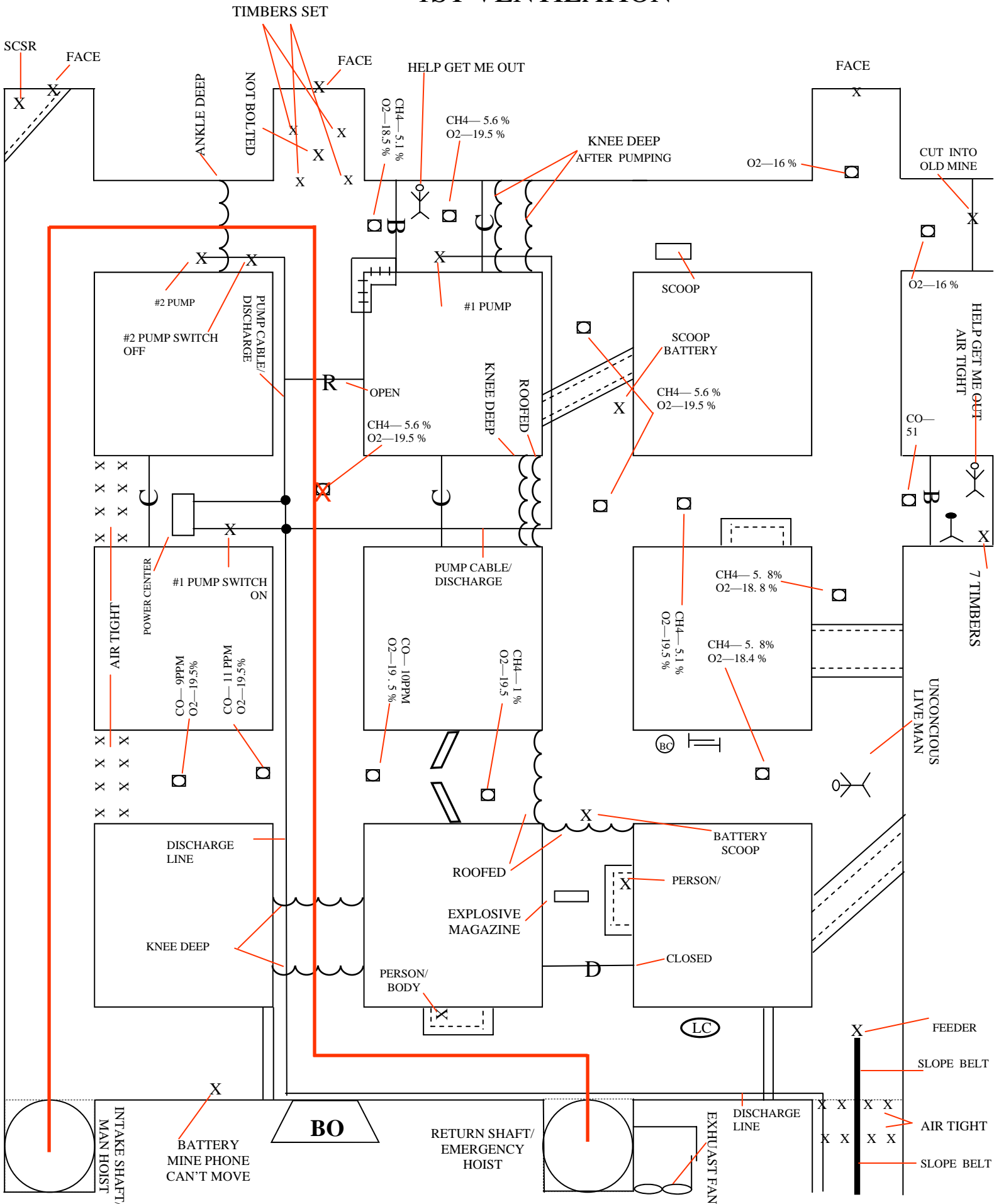

3RD VENTILATION

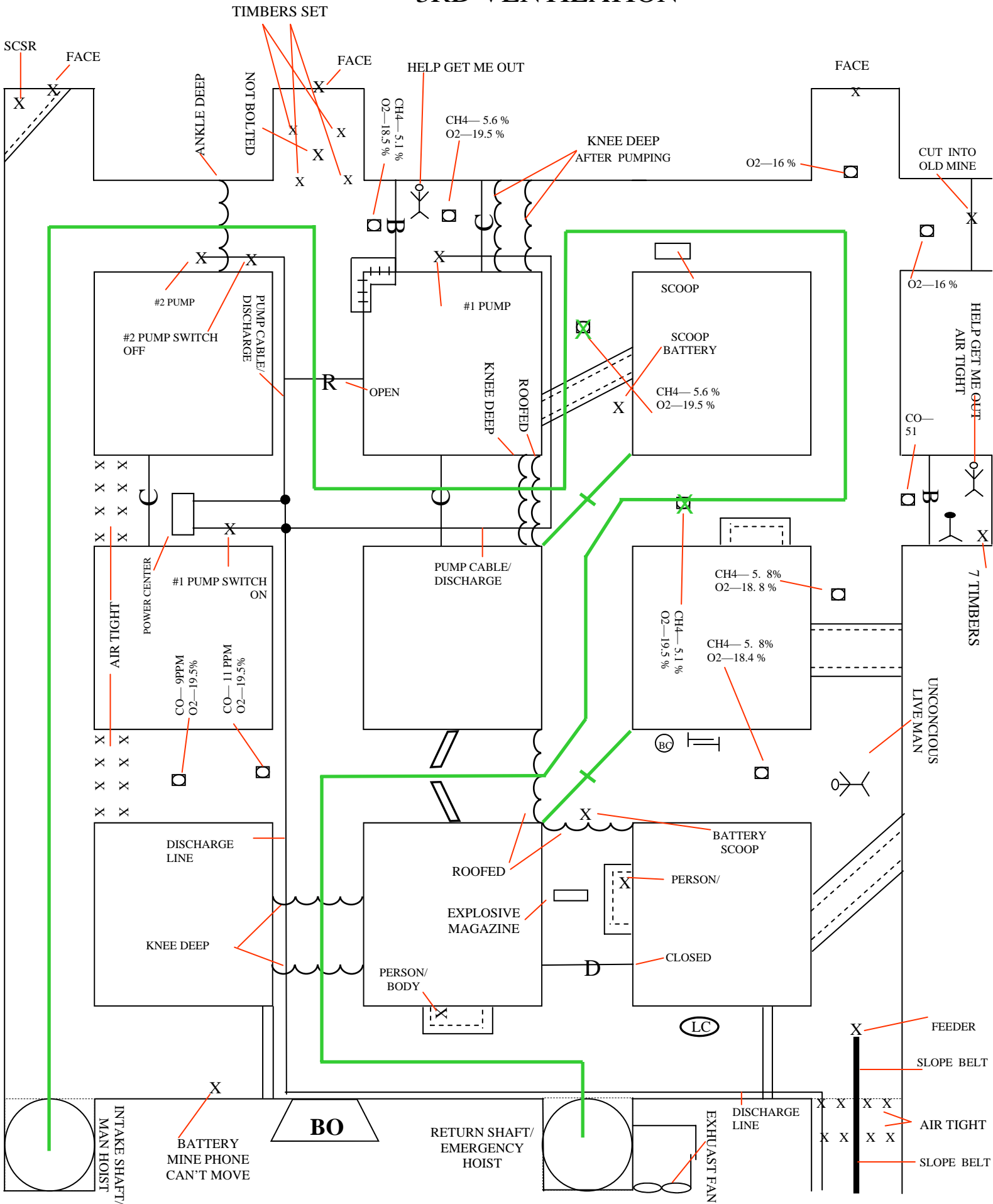

4TH VENTILATION

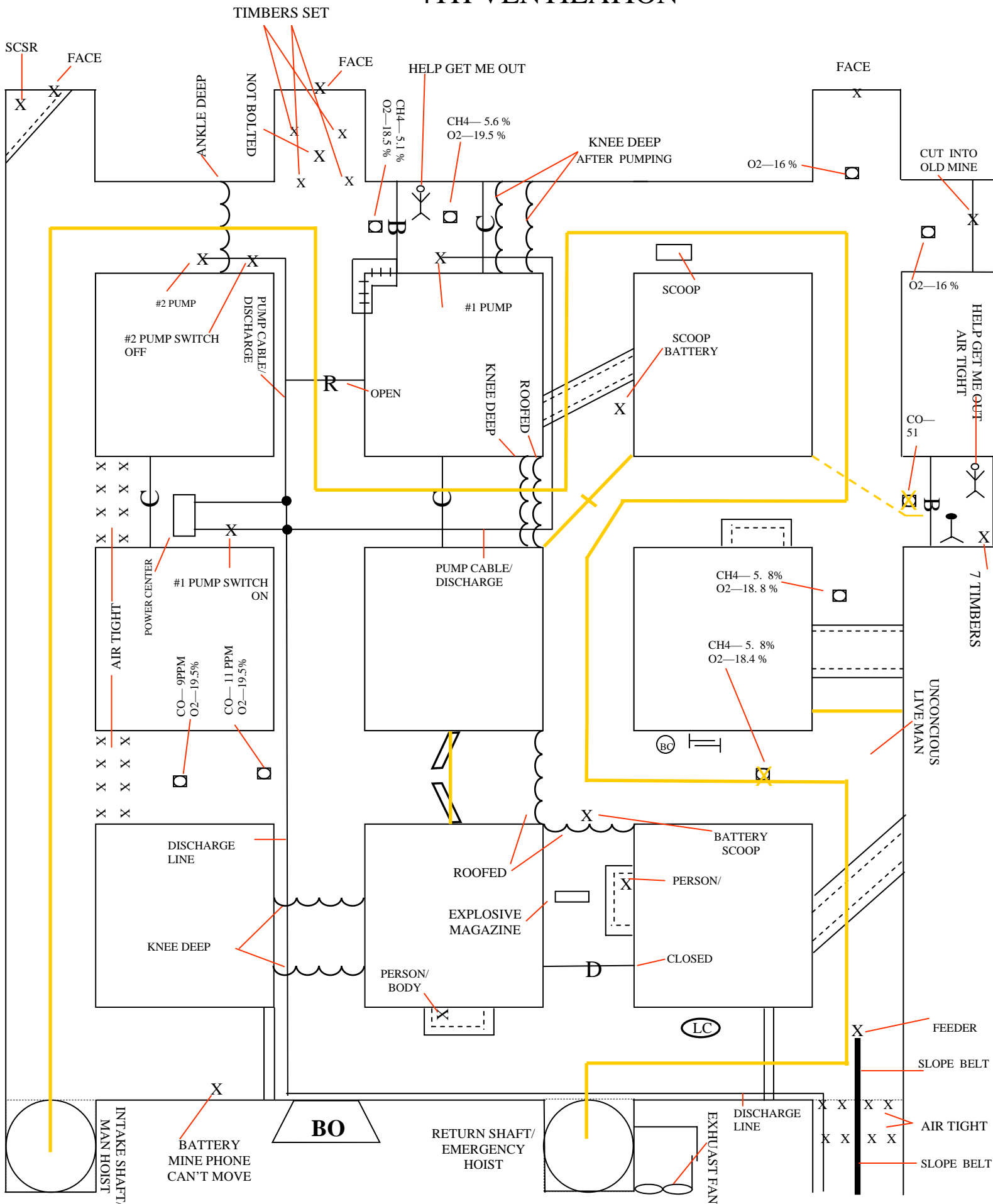

TIMBERS SET

