

WKMI

Mine Rescue Contest

May 26, 2010

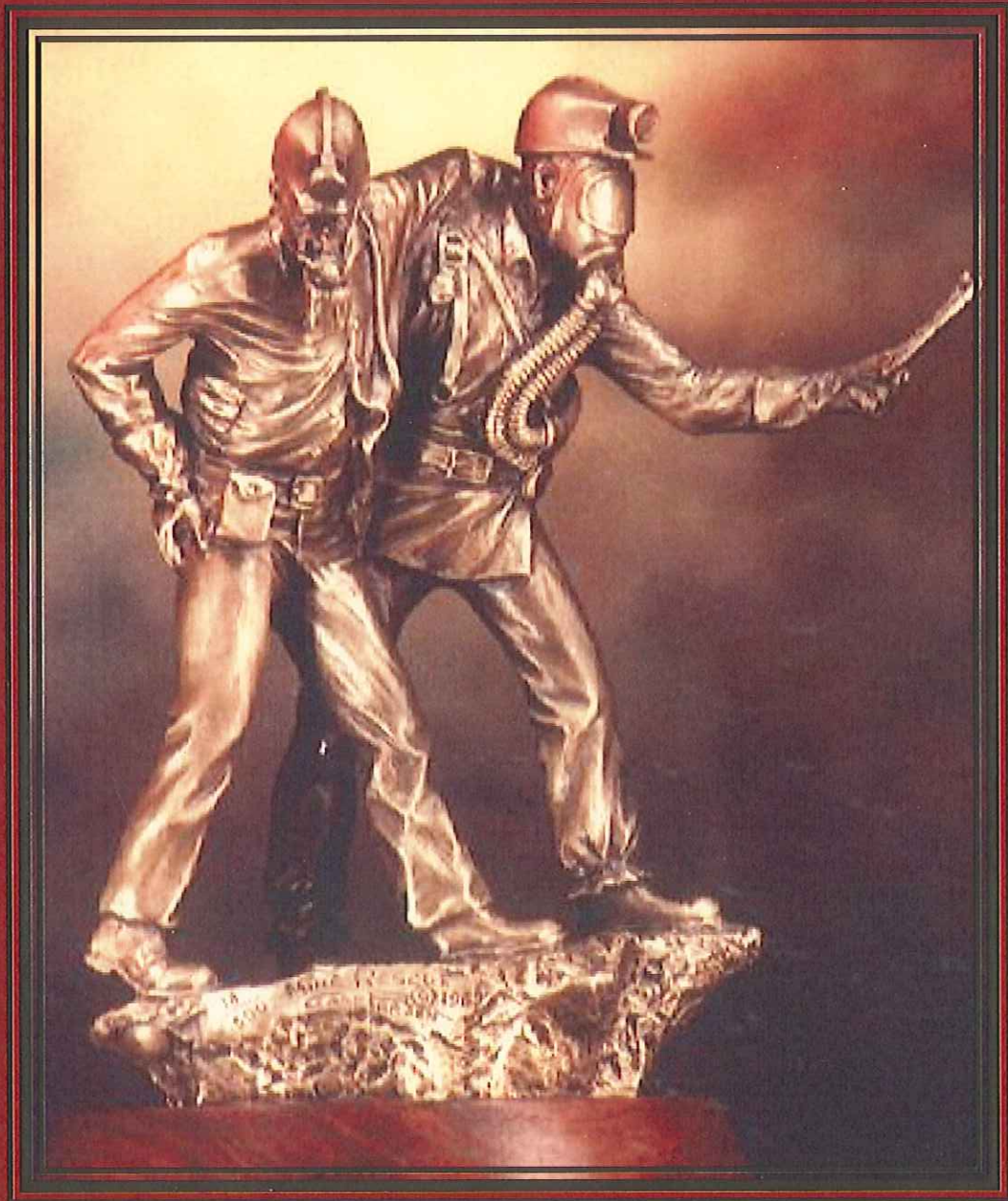

We Train So Others May Live!

2010 WKMI MINE RESCUE CONTEST

	FIELD 1A	FIELD 2A	FIELD 3A	FIELD 4A	FIELD 5A
SUPT.	HAROLD SLONE	TED SMITH	TIM FOSTER	BILL PERKINS	RICHARD WALKER
CHAIRMAN	BILL MILLAY	RICK JOHNSON	BILL COOK	LEE VINCENT	RODNEY JAMES
JUDGE	ANTHONY BENTON	RAY JOHNSON	JOEY SAMONS	CHESTER SLONE	CHALMIER WILLIAMSON
JUDGE	KEVIN BRUNER	BILL BLALOCK	DONNIE ERVIN	BRAD THOMAS	MICHAEL DILLINGHAM
TIMEKEEPER	TIM GARDNER	MARCIE DAILEY	HEATHER SMITH	DAVID WINEBARGER	DENISE LEEDY
LIFELINE					
LIFELINE					
	FIELD 1B	FIELD 2B	FIELD 3B	FIELD 4B	FIELD 5B
SUPT.	LARRY FULLER	ROBERT GRAY	CHARLIE L. JONES	CHARLIE W. JONES	MIKE WHITFIELD
CHAIRMAN	MICHAEL NEWCOM	DOYLE SPARKS	TROY DAVIS	TONY SIMMS	PAT TURNER
JUDGE	DEREK BUSBY	DANNY CRUMPTON	JOHN BOYLEN	GARY OLIVER	DEAN BUSH
JUDGE	CALVIN RIDDLE	CHARLES MADDOX	JOHNNY MORGAN	RANDY PARTIN	BILLY PARROTT
TIMEKEEPER	DYLAN WESTI	AMY GOSSETT	JAIMIE FAITH	STARLA HILL	SHAWNA VANHOOSE
LIFELINE					
LIFELINE					
FIELD LAYOUT					
CHAIRMAN	TONY SANCHEZ	MIKE PARTIN	GENE ADAMS		
	DOUG ROARK	LOUIS ADAMS	JAMES JORDON		
	TONY FAZZLALARE	MARK SHORT	ADAM CARLISLE		
	ELZIA NAPIER	BOBBY HUBBARD	CHRIS WILKERSON		
	RONNIE WHITAKER	DANNY HENDRIX	RANDY BOYD		
			BEN JAMES		

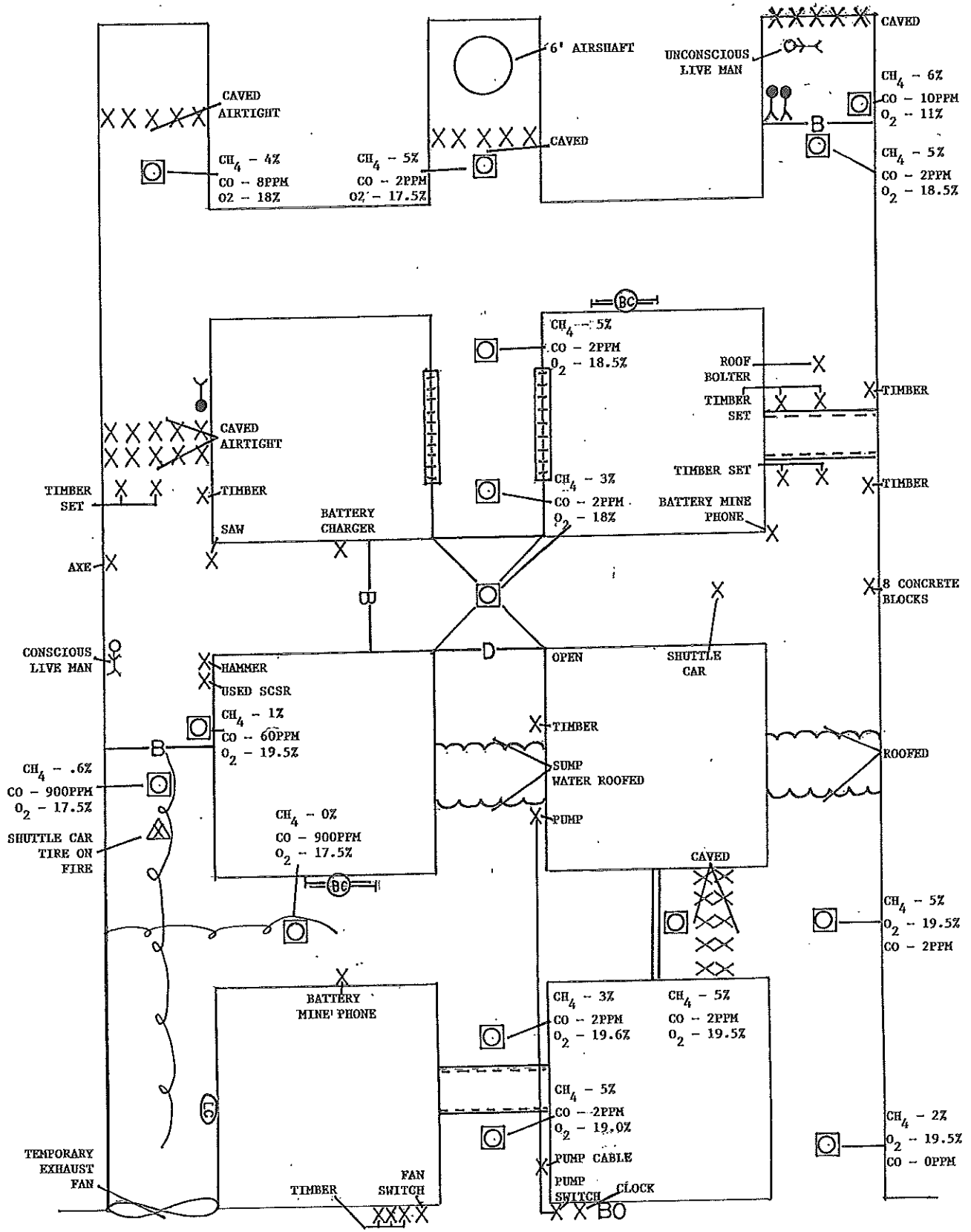

WKMI
 SAFETY DAYS
 MAY 26, 2010

TEAM STOPS

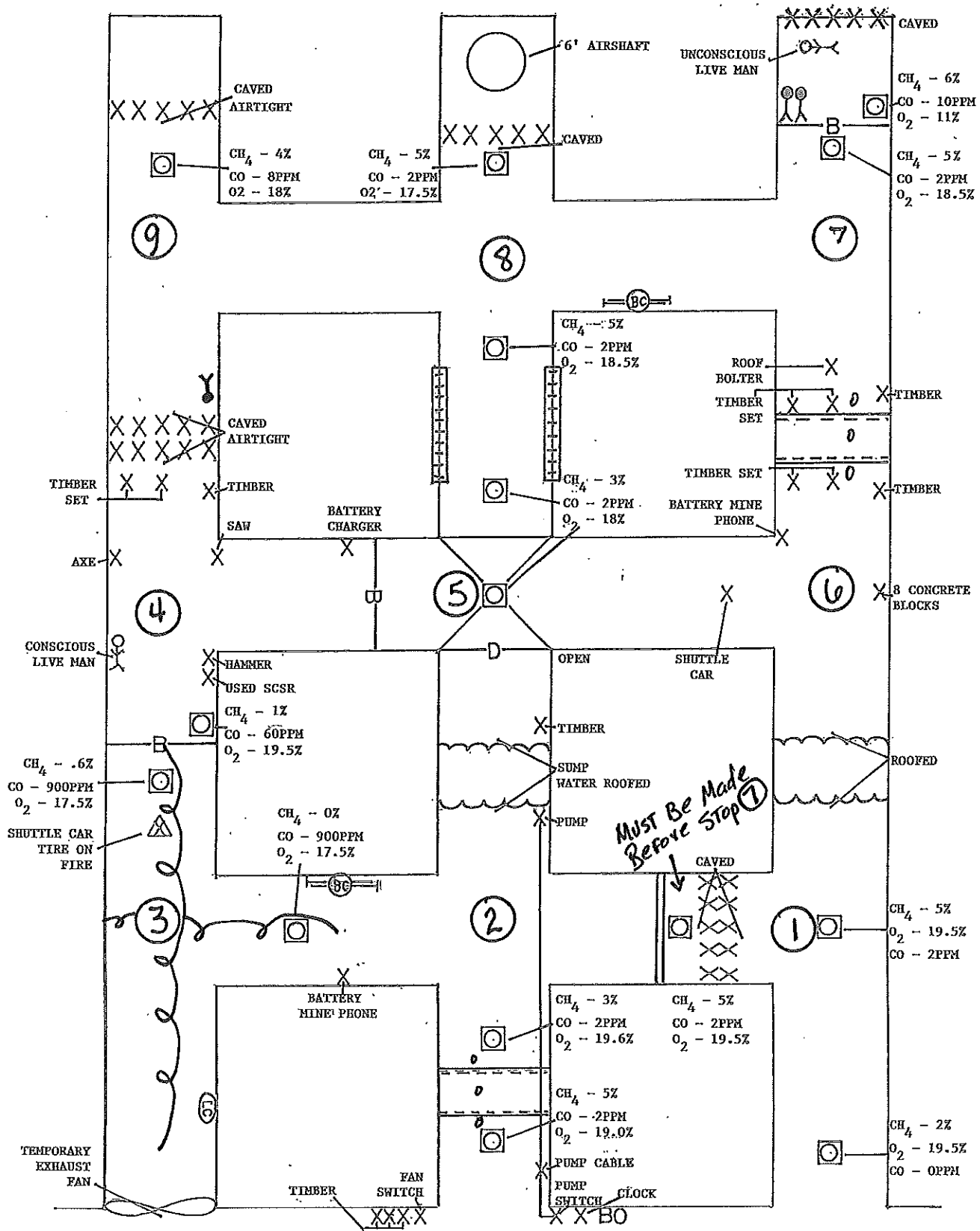

TEAM STOPS

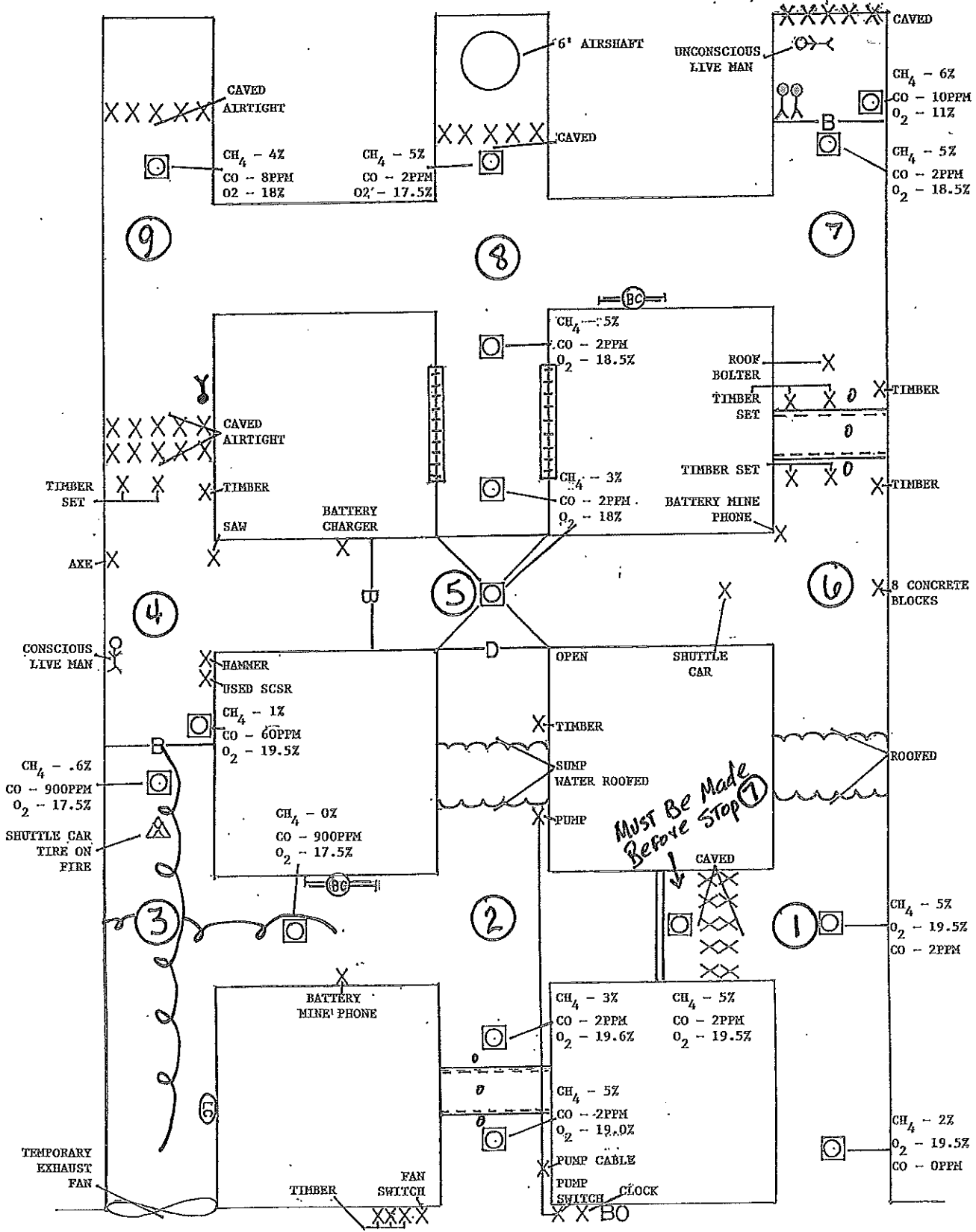

TEAM STOPS

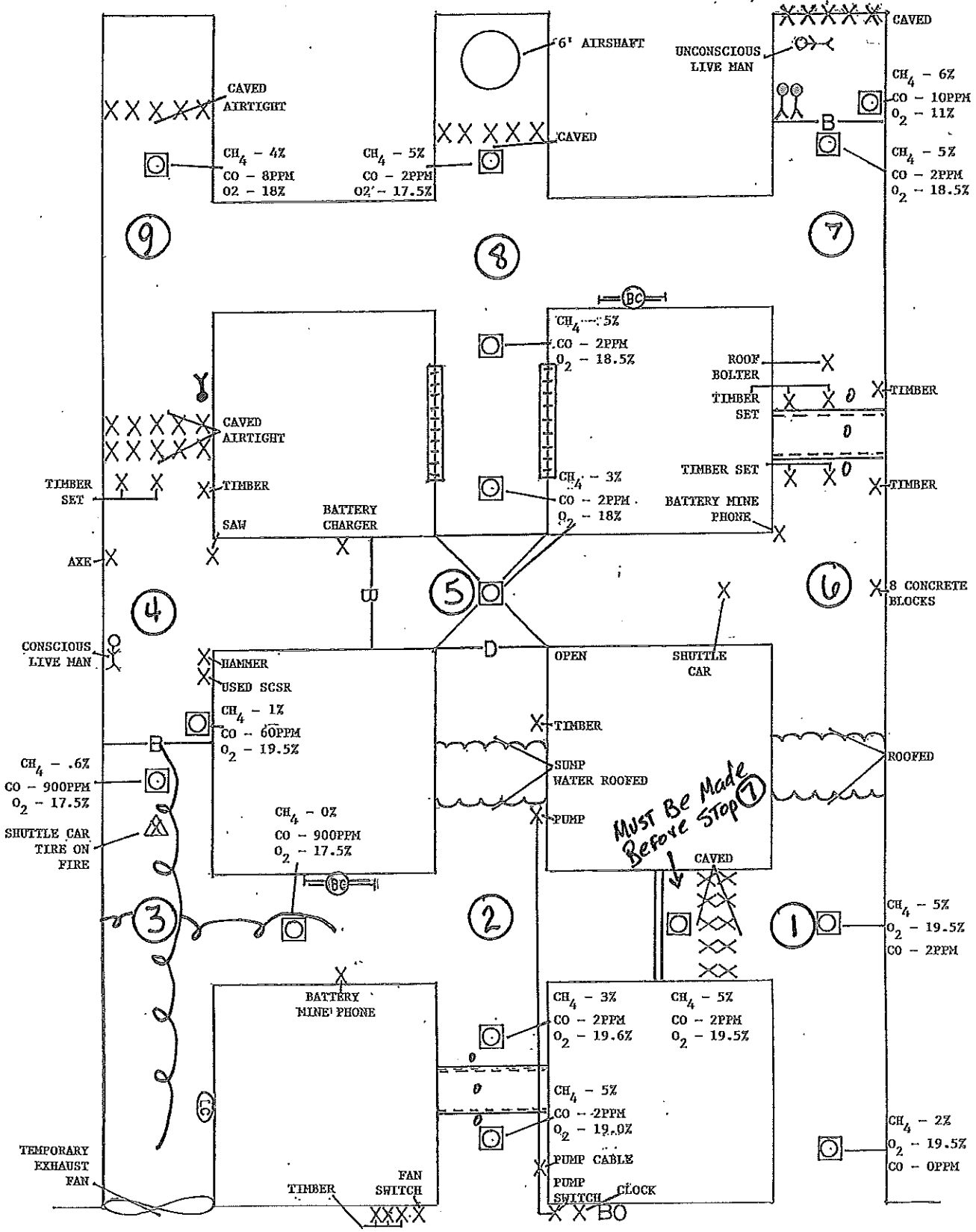

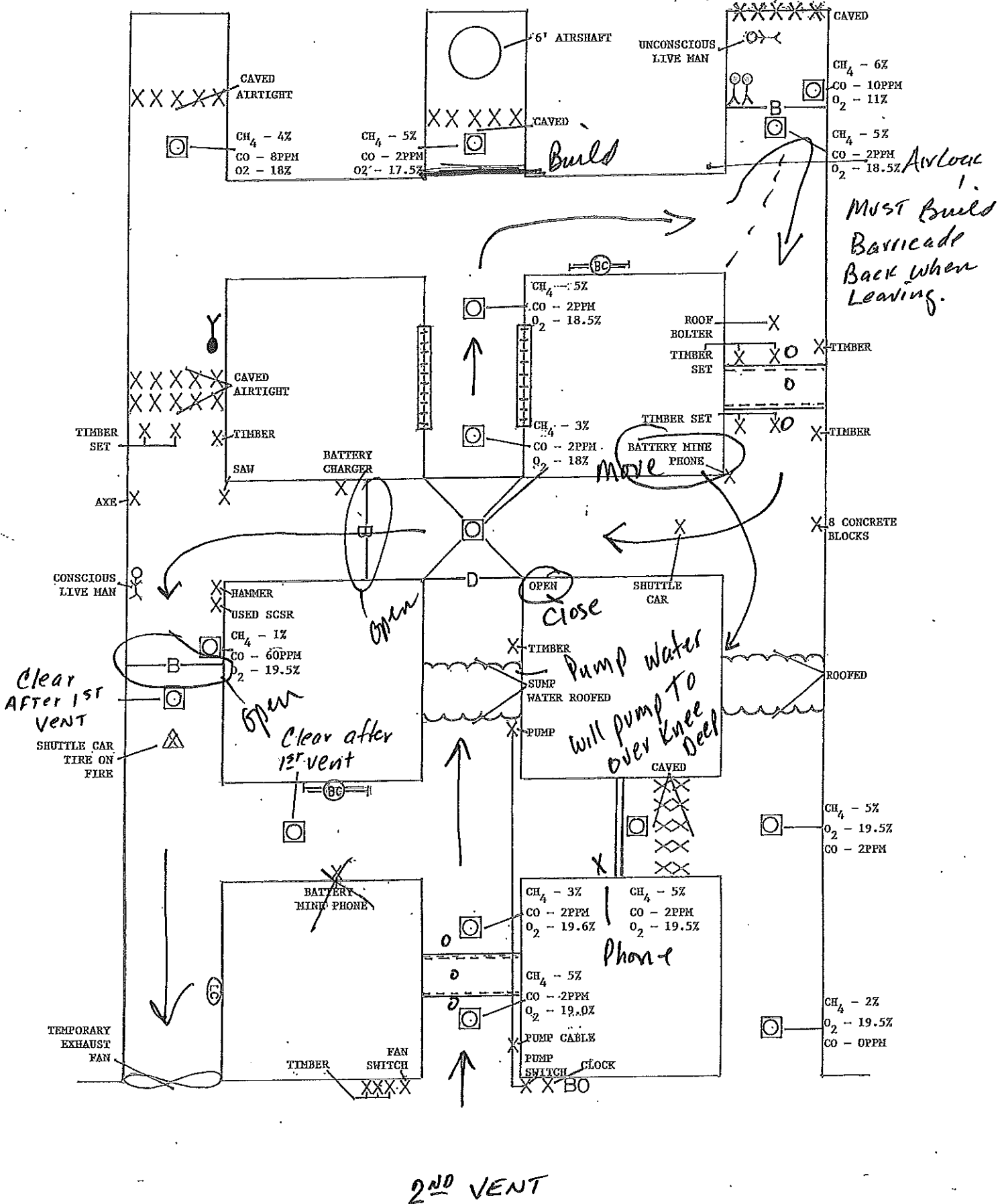

MUST Build Barricade Back when Leaving.

Clear After 1st Vent

Clear after 1st vent

Pump water will pump to over knee deep

2ND VENT

CH₄ - 4%
CO - 8PPM
O₂ - 18%

CH₄ - 5%
CO - 2PPM
O₂ - 17.5%

CH₄ - 6%
CO - 10PPM
O₂ - 11%

CH₄ - 5%
CO - 2PPM
O₂ - 18.5%

CH₄ - 5%
CO - 2PPM
O₂ - 18.5%

CH₄ - 3%
CO - 2PPM
O₂ - 18%

CH₄ - 1%
CO - 60PPM
O₂ - 19.5%

CH₄ - 5%
O₂ - 19.5%
CO - 2PPM

CH₄ - 3%
CO - 2PPM
O₂ - 19.6%

CH₄ - 5%
CO - 2PPM
O₂ - 19.5%

CH₄ - 5%
CO - 2PPM
O₂ - 19.0%

CH₄ - 2%
O₂ - 19.5%
CO - 0PPM

WKMI - WORKING ORDER

1	INDIANA BUREAU OF MINES - INDIANA MINE RESCUE	15	JWR- MINE # 4
2	AMERICAN COAL - AMERICAN COAL TEAM	16	FIVE STAR MINE RESCUE
3	KNIGHT HAWK COAL - BLACK	17	STATE OF ALABAMA - BLUE TEAM
4	PATRIOT COAL - HIGHLAND	18	WARRIOR COAL - CARDINAL TEAM
5	JAMES RIVER COAL - BLUE TEAM	19	MASSEY ENERGY - SOUTHERN WEST VA TEAM
6	KY COAL ACADEMY - MCC TEAM	20	PEABODY ENERGY - GATEWAY
7	PEABODY INDIANA NORTH TEAM	21	PATRIOT COAL - BLUEGRASS TEAM
8	TECO COAL CORP. - BLUE TEAM	22	WEBSTER COUNTY COAL - DOTIKI TEAM
9	ICG KNOTT COUNTY - BLUE TEAM	23	ILLINOIS STATE - BENTON TEAM
10	HOPKINS COUNTY COAL - ELK CREEK	24	PEABODY ENERGY - WILLOW LAKE TEAM
11	STATE OF ALABAMA - GREEN TEAM	25	ICG - VIPER RED TEAM
12	RIVER VIEW COAL- RIVERVIEW TEAM	26	STATE OF ILLINOIS - HARRISBURG TEAM
13	PEABODY INDIANA SOUTH TEAM	27	DRUMMOND COAL - SHOAL CREEK TEAM
14	GIBSON COUNTY COAL - RESCUE RHINOS	28	WHITE COUNTY COAL - PATTIKI